



**Meccanotecnica  
Umbra**

a Story of Excellence



**Meccanotecnica  
Umbra**

a Story of Excellence

**Meccanotecnica Umbra S.p.A.**  
Via Giovanni Agnelli 7/9  
06042 Campello sul Clitunno (PG) - ITALY  
com@mtu-group.com  
www.meccanotecnicaumbra.com

# Hydrodynamic Seals for Aerospace Applications





# Customised Aerospace Performance

The aerospace industry demands sealing solutions that are unique in their kind, capable of meeting high standards in terms of performance.

As critical components of the aircraft, mechanical seals must withstand the most extreme conditions imaginable: high rotational speeds, extreme operating temperatures, as well as variable ranges of working pressures as the aircraft travels at different altitudes.

Meccanotecnica Umbra provides absolutely customized sealing solutions based on design data.

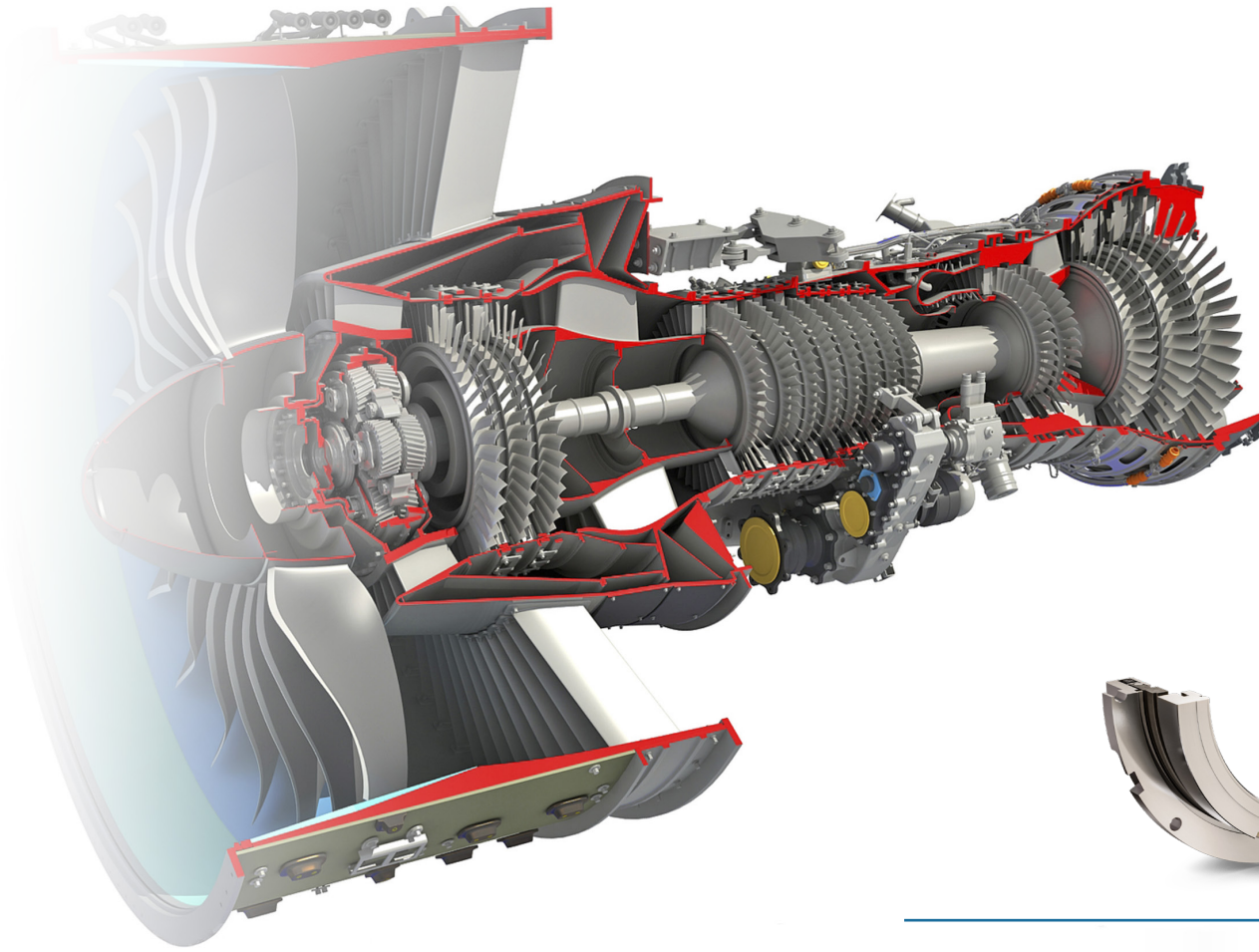

**UFS series**  
**Mechanical Face Seal for ATS**  
 Speed 200m/s max  
 Delta Pressure: 260 kPa  
 Temp. 523°K max



**AGB series**  
**Mechanical Face Seal for GearBox**  
 Speed 150m/s max  
 Delta Pressure: 130 kPa  
 Temp. 523°K max

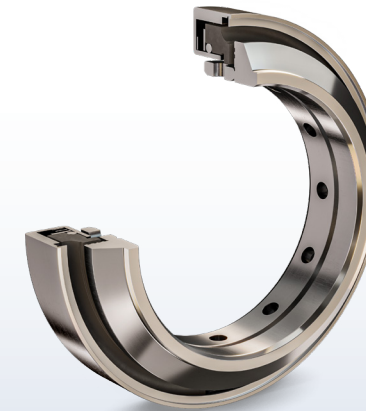

**HGB series**  
**Mechanical Face Seal for GearBox**  
 Speed 100 m/s max  
 Delta Pressure: 130 kPa  
 Temp. 523°K max

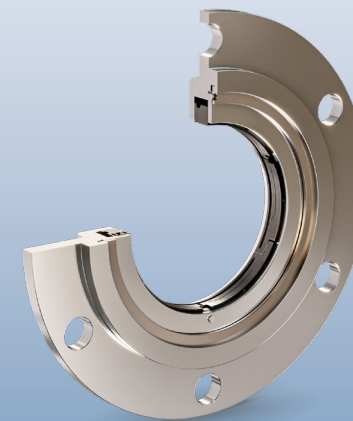

**SRS series**  
**Segmented Radial Seal for APU**  
 Speed 70.000 rpm max  
 Delta Pressure: 130 Kpa  
 Temp. 523°K max

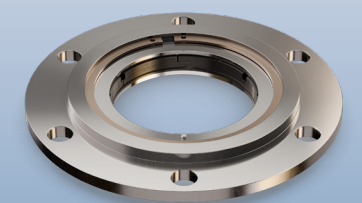

## GearBox

Gearboxes are critical components of helicopters, transmitting power from the engine to the rotating blades. Meccanotecnica Umbra, at its Competence Center in Campello sul Clitunno, designs and manufactures sealing systems for this specific application, employing the latest technologies such as surface texturing.

## Auxiliary Power Units

(APU) are systems that provide power to the aircraft when the main engines are not operational, ensuring the safety and comfort of passengers and crew. They reduce fuel consumption and emissions during ground operations, ensuring the efficiency and proper functioning of the aircraft.

## Air Turbine Starter

(ATS) systems are used to start aircraft turbine engines. Despite their small size and lightweight, ATS systems can generate a considerable amount of torque to start the engine until it can run independently.